

An Enhancement of Power Quality Using Intelligent Unified Power Quality Conditioner to Mitigate Voltage Sag and Swell

M.Subhash¹, V.Sripriya² and Subrahmanyam KBVSR³

¹Department of Electrical Engineering, SR Engineering College, Warangal, India.

²Department of Electrical Engineering, SR Engineering College, Warangal, India,

³Department of Electrical Engineering, SR Engineering College, Warangal, India

Article Received: 24 July 2017

Article Accepted: 08 August 2017

Article Published: 10 August 2017

ABSTRACT

In this paper the power quality improvement is done by mitigating harmonics using the custom power devices like Unified Power Quality Control (UPQC). The UPQC consists of combination of series and shunt active filters. Series filter inject voltage which gets added at the point of common coupling and hence the voltage at the load end gets unchanged with the voltage disturbances. Shunt active filter compensates the load reactive power demand and hence mitigates the harmonics from supply current and also maintains the DC link voltage. Unified power quality conditioner (UPQC) is one modern device which deals with voltage and current imperfections simultaneously. In this paper, an attempt has been made to model the UPQC for voltage and current compensation with the help of two different control schemes. The current and voltage harmonics as well as voltage sag and swells compensation are analyzed MATLAB/SIMULINK software.

Keywords: UPQC, Series Active filter, Shunt active filter and THD.

1. INTRODUCTION

Power quality is defined as the concept of powering and grounding electronic equipment in a manner that is suitable to the operation of that equipment and compatible with the premise wiring system and other connected equipment in Institute of Electrical and Electronics Engineers (IEEE) Standard 1159-1995 (IEEE std. 519, 1995). International Electro technical Commission (IEC) defined power quality as set of parameters defining the properties of power quality as delivered to the user in normal operating conditions in terms of continuity of supply and characteristics of voltage (frequency, magnitude, waveform and symmetry). [1]

There are two classes of power quality problems: phenomena due to low quality of current drawn by the load caused by nonlinear loads and voltage disturbances that cause faults in the power system. The most significant and critical power quality problems are voltage sags, voltage swells and current harmonics. [2] These problems may cause tripping of sensitive electronic equipment with disastrous consequences in industrial plants where tripping of critical equipment can bear the stoppage of the whole production with high costs associated. [3-5]

Custom Power devices also called as power quality compensator employ power electronic or static controllers in medium or low voltage distribution systems for the purpose of supplying a level of power quality that is needed by electric power customers that are sensitive to root mean square (RMS) voltage variations and voltage transients. [6,7] CP devices include static switches, power converters, injection transformers, master control modules and/or energy storage modules that have the ability to perform current interruption and voltage regulation functions in a distribution system to improve power quality. CP devices are generally used for voltage regulation, active filtering, load balancing or power factor correction.

Active Power Filter is a shunt connected compensating device. The main purpose of this device is to protect supply currents from current harmonics in the load side (downstream). This is accomplished by rapid shunt current injection to compensate for the harmonics in the load current. Dynamic Voltage Restorer is a series connected compensating device that protects sensitive loads from sag/swell disturbances in the supply side (upstream). This is performed by rapid series voltage injection to compensate for the drop/rise in the supply voltage. [8]

In recent years, Unified Power Quality Conditioner which offers customers high quality of power has become an increased concern of engineers. UPQC is a combination of a shunt (APF) and a series compensator (DVR) connected together via a common direct current (DC) link capacitor. [9] These devices compensate the power quality disturbances such as current harmonics and voltage sag/swell to protect sensitive process loads as well as improve service reliability. However, these devices do not allow local distributors to guarantee different quality demand levels to the final customers, because they improve power quality for all the supplied end users. The installation investments are also quite high relative to the power quality level obtained. [10]

A solution that has similar performances and advantages, but also makes cost reduction possible, is OPEN UPQC. This new solution, analyzed in (Morris et al., 2009) as a simulation study, starts from UPQC configuration and removes the common DC connection. Therefore, the control strategy is different than the traditional combined series and shunt converters. Above all, OPEN UPQC can stabilize load voltage, keep load voltage and supply current sinusoidal and balanced as well. [11]

The combination of APF and DVR concept being relatively new is still being researched. It is considered that this will be

a universal solution to all power quality issues because of its voltage and current compensating capability. In order to achieve the mitigation of PQ disturbances, new circuit topologies for UPQC and new control techniques to detect and extract the PQ disturbances should be examined. [12]

In this paper the follow objectives for the proposed UPQC are set and important contributions of this concept can be summarized as follows:

(i) OPEN UPQC is investigated as experimentally in UPQC literature for the first time. OPEN UPQC is a relatively new device and not much work has yet been reported on its theoretical, design procedure and experimental analysis. The publications made as a result of this thesis will contribute to scientific literature. This thesis will also contribute to the concept finding solutions to the electric power quality problems and this will also pioneer the using of related devices in the world.

(ii) APF control algorithm is optimized for harmonic compensation of load current under unbalanced supply voltages. The disadvantage of IRPT theory under unbalanced supply voltages is eliminated by creating virtual alpha and beta components. The number of voltage measurement points has been reduced using this control approach.

(iii) An algorithm for unbalanced voltage sag detection is presented. A passive filter with a low cut-off frequency is not used in the sag detection. The proposed method can detect the single-phase voltage sags correctly. The extraction and tracking of disturbances are fast and accurate when compared with the traditional detection methods. Each phase of DVR is controlled independently thus minimum voltage injection is obtained during unbalanced faults. During the standby operation of DVR, two lower IGBTs in each phase remain turned on while the two upper IGBTs remain turned off.

A reference voltage generation method is presented which is used in a voltage compensation of DVR. Most of the methods in literature have drawbacks to generate compensation signals experimentally when the supply voltage is distorted and unbalanced. With this approach, "distortions in the supply line are perfectly filtered" and a purely sinusoidal reference voltage is obtained.

2. PROPOSED UPQC DESIGN

The Unified Power Quality Conditioner is a custom power device that is employed in the distribution system to mitigate the disturbances that affect the performance of sensitive and/or critical load [13]. It is a type of hybrid APF and is the only versatile device which can mitigate several power quality problems related with voltage and current simultaneously therefore is multi functioning devices that compensate various voltage disturbances of the power supply, to correct voltage fluctuations and to prevent harmonic load current from entering the power system. Fig. 1 shows the system configuration of a single-phase UPQC. Unified Power Quality Conditioner (UPQC) consists of two IGBT based Voltage source converters (VSC), one shunt and one series cascaded by a common DC bus. The shunt converter is connected in parallel to the load. It provides

VAR support to the load and supply harmonic currents. Whenever the supply voltage undergoes sag then series converter injects suitable voltage with supply [14]. Thus UPQC improves the power quality by preventing load current harmonics and by correcting the input power factor.

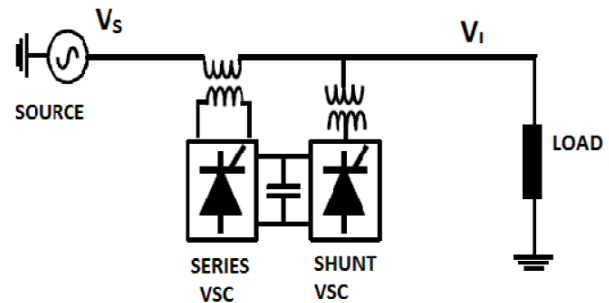

Fig.1. Block diagram of UPQC

A. Basic Configuration of UPQC

The main components of a UPQC are series and shunt power converters, DC capacitors, low-pass and high-pass passive filters, and series and shunt transformers:

Series converter

It is a voltage-source converter connected in series with the AC line and acts as a voltage source to mitigate voltage distortions.

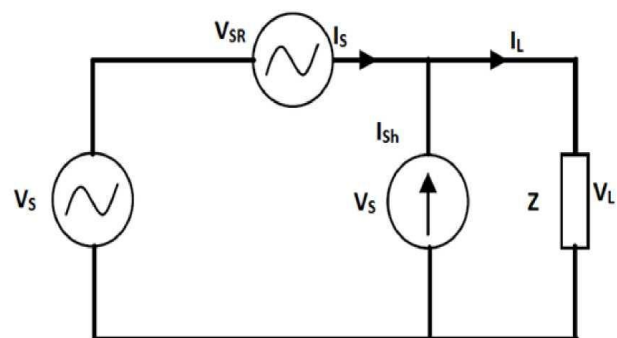

Fig.2 Equivalent circuit for UPQC

It is used to eliminate supply voltage flickers or imbalance from the load terminal voltage and forces the shunt branch to absorb current harmonics generated by the nonlinear load. Control of the series converter output voltage is usually performed using sinusoidal pulse-width modulation (SPWM). The gate pulses required for converter are generated by the comparison of a fundamental voltage reference signal with a high-frequency triangular waveform.

Shunt converter

It is a voltage-source converter connected in shunt with the same AC line and acts as a current source to cancel current distortions, compensate reactive current of the load, and improve the power factor. It also performs the DC-link voltage regulation, resulting in a significant reduction of the DC capacitor rating. The output current of the shunt converter is adjusted using a dynamic hysteresis band by controlling the status of semiconductor switches so that output current follows the reference signal and remains in a predetermined hysteresis band.

Midpoint-to-ground DC capacitor bank

It is divided into two groups, which are connected in series. The neutrals of the secondary transformers are directly connected to the DC link midpoint. As the connection of both three-phase transformers is Y/Y₀, the zero-sequence voltage appears in the primary winding of the series-connected transformer in order to compensate for the zero-sequence voltage of the supply system. No zero-sequence current flows in the primary side of both transformers. It ensures the system current to be balanced even when the voltage disturbance occurs.

Low-pass filter

It is used to attenuate high frequency components at the output of the series converter that are generated by high-frequency switching.

High-pass filter

It is installed at the output of shunt converter to absorb current switching ripples.

Series and shunt transformers

These are implemented to inject the compensation voltages and currents, and for the purpose of electrical isolation of UPQC converters. The UPQC is capable of steady-state and dynamic series and/or shunt active and reactive power compensations at fundamental and harmonic frequencies. However, the UPQC is only concerned about the quality of the load voltage and the line current at the point of its installation, and it does not improve the power quality of the entire system.

3. EQUIVALENT CIRCUIT

In this circuit,

V_S represent the voltage at power supply
 V_{SR} is the series-APF for voltage compensation,
 V_L represents the load voltage and
 I_{sh} is the shunt-APF for current and V_{SR} compensation.
 Due to the voltage Distortion, the system may contain negative phase sequence and harmonic components.

In general, the source voltage in Figure 2 can be expressed as:
 $V_s + V_{sr} = V_L$ 1.1

To obtain a balance sinusoidal load voltage with fixed amplitude V, the output voltages of the series-APF should be given by:

$$V_{sr} = (V - V_{lp}) \sin(\omega t + \theta_{lp}) - V_{Ln}(t) - \sum_{k=2}^{\infty} V_k(t)$$

Where,

V_{lp}: positive sequence voltage amplitude fundamental frequency

θ_{lp}: initial phase of voltage for positive sequence

V_{ln}: negative sequence component

The shunt-APF acts as a controlled current source and its output components should include harmonic, reactive and negative-sequence components in order to compensate these quantities in the load current, when the output current of shunt APF *i_{sh}* is kept to be equal to the component of the load as given in the following equation:

$$i_L = I_{lp} \cos(\omega t + \theta_{lp}) \sin \varphi_{lp} + i_{Ln} + \sum_{k=2}^{\infty} i_{Lk}$$

$$\theta_{lp} = \varphi_{lp} - \theta_{lp}$$

Where, φ_{lp}: initial phase of current for positive sequence
 As seen from the above equations that the harmonic, reactive and negative sequence current is not flowing into the power source. Therefore, the terminal source current is harmonic-free sinusoid and has the same phase angle as the phase voltage at the load terminal

$$i_s = i_L - i_{sh} = I_{lp} \sin(\omega t - \theta_{lp}) \cos \varphi_{lp}$$

UPQC Configurations

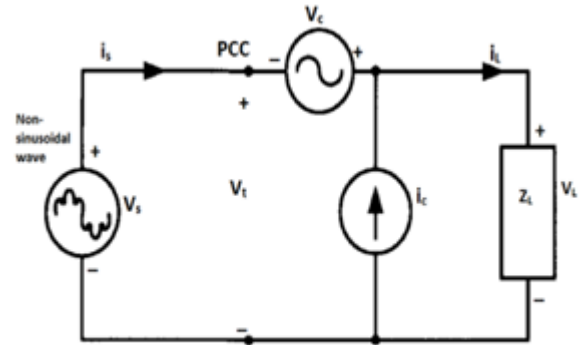

Fig 3 Left shunt UPQC compensation configuration

There are two possible ways of connecting the unit to the terminal voltage (V_L) at PCC:

- Right-shunt UPQC (figure4.3), where the shunt compensator (i_c) is placed at the right side of the series compensator (V_c).
- Left-shunt UPQC (figure4.4), where the shunt compensator (i_c) is placed at the left side of the series compensator (V_c).

These two structures have similar features; however the overall characteristics of the right shunt UPQC are superior (e.g. operation at zero power injection/absorption mode, achieving unity power factor at load terminals, and full reactive power compensation) [1].

4. STEADY - STATE POWER FLOW ANALYSIS

The powers due to harmonic quantities are negligible as compared to the power at fundamental component, therefore, the harmonic power is neglected and the steady state operating analysis is done on the basis of fundamental frequency component only. The UPQC is controlled in such a way that the voltage at load bus is always sinusoidal and at desired magnitude. Therefore the voltage injected by series APF must be equal to the difference between the supply voltage and the ideal load voltage. Thus the series APF acts as controlled voltage source. The function of shunt APF is to maintain the dc link voltage at constant level. In addition to this the shunt APF provides the VAR required by the load, such that the input power factor will be unity and only fundamental active power will be supplied by the source

Case I

The reactive power flow during the normal working condition when UPQC is not connected in the circuit is shown in the Fig. 4.4 a. In this condition the reactive power required by the load is completely supplied by the source

only. When the UPQC is connected in the network and the shunt APF is put into the operation, the reactive power required by the load is now provided by the shunt APF alone; such that no reactive power burden is put on the mains. So as long as the shunt APF is ON, it is handling all the reactive power even during voltage sag, voltage swell and voltage harmonic compensation. The series APF does not take any active part in supplying the load reactive power demand. The reactive power flow during the entire operation of UPQC is shown in the Fig. 4.4 (b).

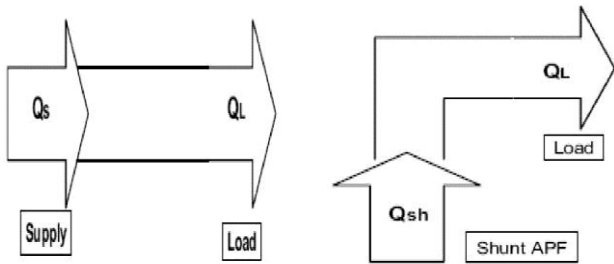

Fig 4 Reactive Power Flow No UPQC (b) Shunt APF ON

- V_s = Source Voltage
- V_t = terminal Voltage at PCC load
- V_L = Load voltage
- I_s = source current
- I_L = Load current
- V_{sr} = voltage injected by series APF
- I_{sr} = current injected by shunt APF
- K = fluctuation of source voltage

Case II

If $k < 0$, i.e. $v_t < v_b$, P_{sr} will be positive, means series APF supplies the active power to the load. This condition is possible during the utility voltage sag condition. I_s will be more than the normal rated current. Thus we can say that the required active power is taken from the utility itself by taking more current so as to maintain the power balance in the network and to keep the dc link voltage at desired level.

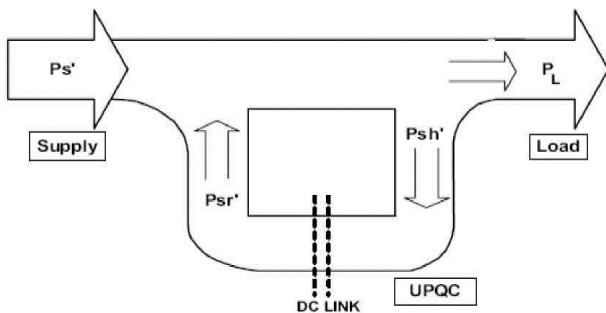

Figure 5 Active power flow during voltage sag condition

- P_s = Power supplied by the source to the load during voltage sag conditions
- P_{sr} = Power injected by series APF in such way that sum $P_{sr} + P_s$ will be the required load power during normal working conditions i.e., P_L
- P_{sh} = Power absorbed by shunt APF during voltage sag conditions $P_{sr} = P_{sh}$

This active power flows from the source to shunt APF, from shunt APF to series APF via dc link and finally from series APF to the load. Thus the load would get the desired power even during voltage sag condition. Therefore in such cases

the active power absorbed by shunt APF from the source is equal to the active power supplied by the series APF to the load. The overall active power flow is shown in Fig. 4.5.

Case III

If $k > 0$, i.e. $v_t > v_b$, P_{sr} will be negative, this means series APF is absorbing the extra real power from the source. This is possible during the voltage swell condition. i_s will be less than the normal rated current. Since v_s is increased, the dc link voltage can increase. To maintain the dc link voltage at constant level the shunt APF controller reduces the current drawn from the supply. In other words we can say that the UPQC feeds back the extra power to the supply system. The overall active power flow is shown in Fig. 6

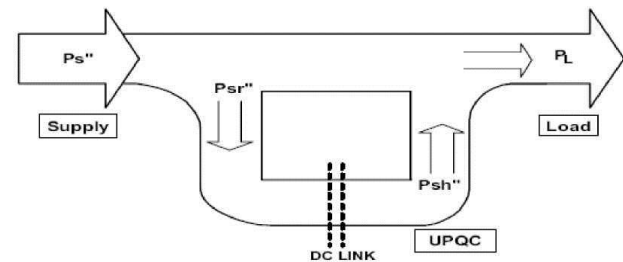

Fig. 6 Active power flow during voltage swells condition

- P_s'' = Power Supplied by the source to the load during voltage swell condition
- P_{sr}'' = Power Injected by Series APF in such way that sum $P_s'' - P_{sr}''$ will be the required load power during normal working condition
- P_{sh}'' = Power delivered by shunt APF during voltage sag condition $P_{sr}'' = P_{sh}''$

Case IV

If $k = 0$, i.e. $v_t = v_b$, then there will not be any real power exchange though UPQC. This is the normal operating condition. The overall active power flow is shown in Fig..7.

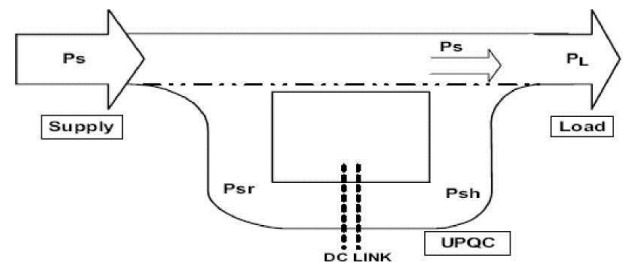

Fig.7 Active Power Flow during Normal working condition

The phasor representations of the above discussed conditions are shown in the Fig. 4.8 (a) - (d). Phasor 4.8(a) represents the normal working condition, considering load voltage V_t as a

reference phasor. ϕ_t is lagging power factor angle of the load. During this condition i_s will be exactly equal to the i_l since no compensation is provided. When shunt APF is put into the operation, it supplies the required load VARs by injecting the leading current such that the source current will be in phase with the terminal voltage. The phasor representing this is shown in Fig. 4.8 (b). The phasor representations during voltage sag and voltage swell condition on the system are shown in the Fig. 4.8 (c) and Fig. 4.8 (d) respectively. The deviation of shunt compensating current phasor from quadrature relationship with terminal

voltage suggests that there is some active power flowing through the shunt APF during these conditions.

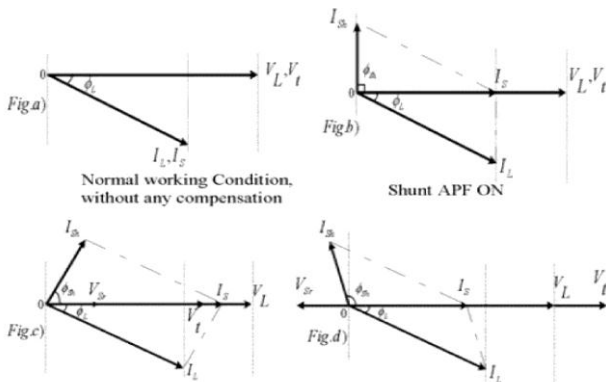

Fig 8 (a) – (d): Phasor Representation of all possible conditions

In normal operating condition, the shunt APF provides the load VAR, whereas, series APF handles no active or reactive power, so in this case the rating of series APF should be small fraction of load rating. The shunt APF rating mainly depends on the compensating current provided by it, which depends on the load power factor or load VAR requirement. Lower the load power factor or higher the load VAR demand, higher would be the shunt APF rating. For the series APF rating depends on two factors; source current i_s and factor k . The current i_s increases during voltage sag condition whereas decreases during voltage swell condition. Therefore the rating of series APF is considerably affected by the % of sag need to be compensated. Since during voltage sag condition the increased source current flows through shunt APF, increasing the shunt APF rating too. Moreover, the shunt APF rating further affected during voltage sag / swell compensation, since it has to maintain the dc link voltage at constant level, which is done by taking requisite amount of active power from the source. A compromise can be made while considering shunt and series APF device ratings, which directly affects the sag/swell compensation capability of UPQC.

5. CONTROL PHILOSOPHY

A controller is required to control the working of UPQC whenever any fault there for this purpose pi controller is used. For DVR control load voltage is sensed and passed through a sequence analyzer. The magnitude of the actual voltage is compared with reference voltage (V_{ref}). Pulse width modulation (PWM) control system is applied for inverter switching so as to generate a three phase sinusoidal voltage at the load terminals. Chopping frequency is in the range of a few KHz. The IGBT inverter is controlled with PI controller in order to maintain 1p.u. voltage at the load terminals. PI controller input is an actuating signal which is the difference between the V_{ref} and V_{in} .

For STATCOM control load current is sensed and passed through a sequence analyzer. The magnitude of the actual current is compared with reference current (I_{ref}). Pulse width modulation (PWM) control system is applied for inverter switching so as to generate a three phase sinusoidal current at the load terminals. Chopping frequency is in the range of a

few kHz. The IGBT inverter is controlled with PI controller in order to maintain 1p.u. current at the load.

PI Controller

A PI-Lead controller is a proportional gain in parallel with an integrator; both in series with a lead controller. The proportional gain provides fast error response. The integrator drives the system to a steady-state error. PI controller is one of the most widely sought after controller in industry as it is the simplest to design.

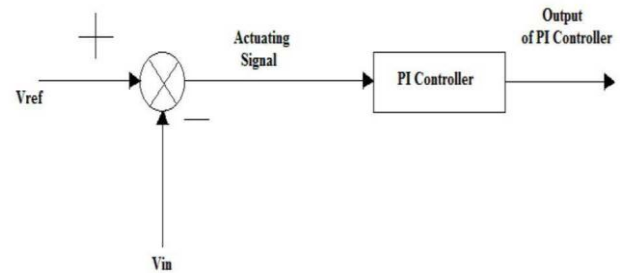

Figure 9: PI Control

Proportional (Gain)

'P' is Proportional control in which the output varies based on how far you are from your target. The error is multiplied by a negative (for reverse action) proportional constant P, and added to the current output. P represents the band over which a controller's output is proportional to the error of the system. E.g. for a heater, a controller with a proportional band of 10 deg C and a set point of 100 deg C would have an output of 100% up to 90 deg C, 50% at 95 Deg C and 10% at 99 deg C. If the temperature overshoots the set point value, the heating power would be cut back further. Proportional only control can provide a stable process temperature but there will always be an error between the required set point and the actual process temperature.

Integral (Reset)

'I' is an Integral control in which the output varies based on how long it's taking you to get to your target. The error is integrated (averaged) over a period of time, and then multiplied by a constant 'I', and added to the current control output. 'I' represent the steady state error of the system and will remove set point / measured value errors. For many applications Proportional + Integral control will be satisfactory with good stability and at the desired set point.

6. SIMULATION & RESULTS

A System is developed to simulate Unified Power Quality Conditioner using PI Control in MATLAB. The complete UPQC is composed mainly of three phase source, a nonlinear load, a voltage source PWM converter and PI Controller. All these components are modeled separately, integrated and then solved to simulate the system.

Figure 5.2 - 5.6 show the simulations results of the proposed UPQC controlled by PI Control with MATLAB program. The parameters selected for simulation studies are given in table 5.1. The three phase source voltages contain harmonics, sag in voltage and swell in voltage in particular period of time. A load with highly nonlinear characteristic is considered for the load compensation. The THD in the load current is 22.24 %. The phase A load current is shown in

figure 5.2. The source current is equal to load current when the compensator is not connected.

Table I System Parameters for Simulation Study

SYSTEM PARAMETERS	VALUES
SOURCE VOLTAGE (V_s)	380 V (RMS ph-ph)
SYSTEM FREQUENCY (f)	50 Hz
TRANSFORMER SERIES	4KVA , 380V/380v
FILTER IMPEDANCE (R_f, L_f)	0.1 Ω , 50 mH
LOAD IMPEDANCE (R_L, L_L)	60 Ω , 0.15 mH
DC LINK CAPACITANCE	5000 μ F
REFERENCE DC LINK VOLTAGE	800 V

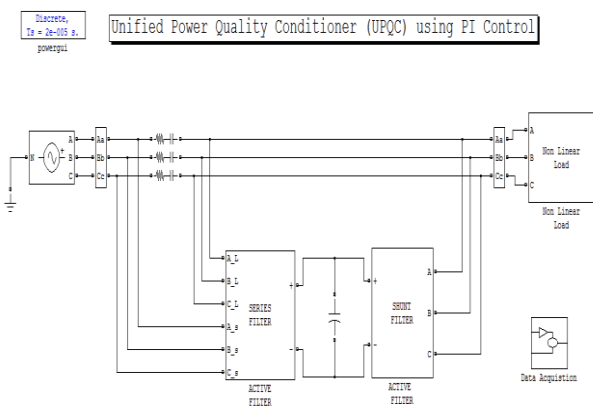

Fig10. MATLAB model of UPQC using PI Control

An ideal three phase sinusoidal supply voltage is applied to the non-linear injecting current and voltage harmonics into the system.

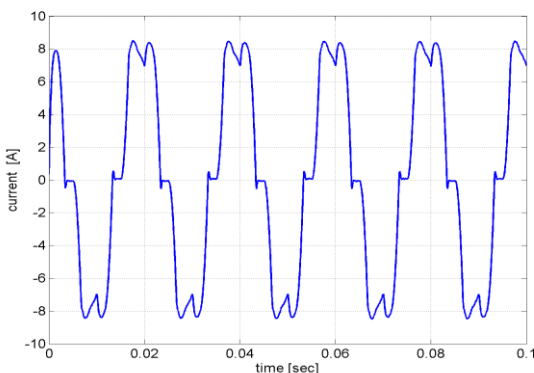

Fig 11 Source current when the compensator is not connected

The UPQC is switched ON at $t = 0.04s$ and the integral time square error (ITSE) performance index is used for optimizing the and coefficients of the PI controller. The source current

before and after compensating along with compensating current is Fig 12.

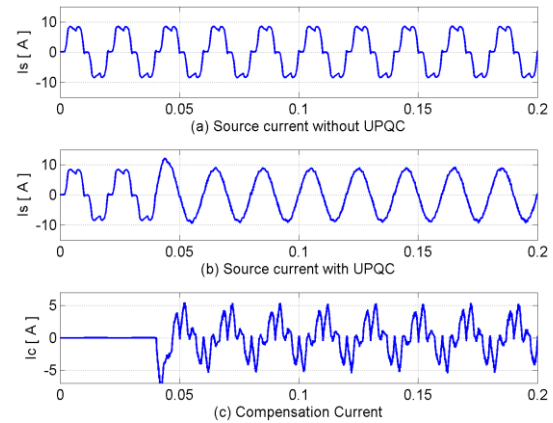

Fig 12 Shunt compensation of UPQC

Before shunt compensation grid current has a THD level of 22.24% and after compensation THD of grid current is 4.46% which is below IEEE standards.

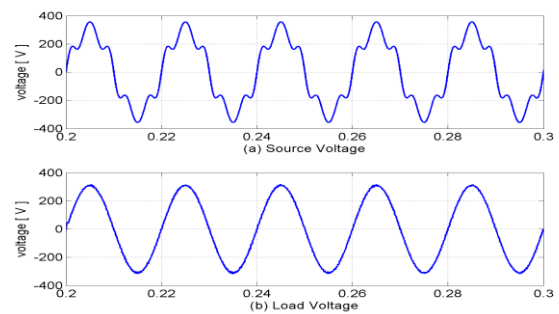

Fig 13 Series compensation for Grid voltage contains harmonics

Fig 14 show the grid voltage contains harmonics with THD of 20.62%. The series compensation of UPQC injects compensating voltage which nullifies the harmonics in the voltage. The tested voltage reduces the THD to 1.66%.

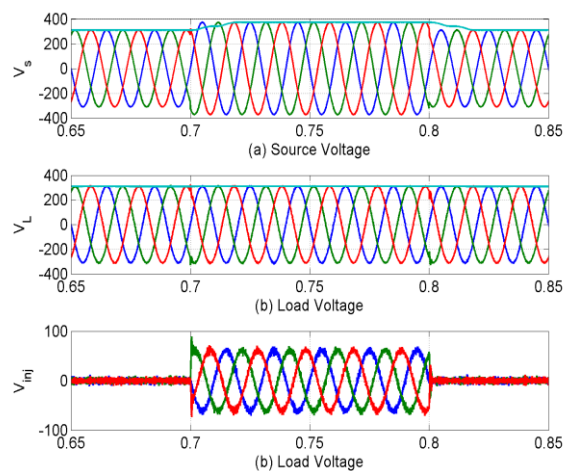

Fig 14 Mitigation of Swell in Load Voltage

Figure 14 shows the grid voltage contains 20% higher than the nominal value. Series active filter reduced the value to nominal value

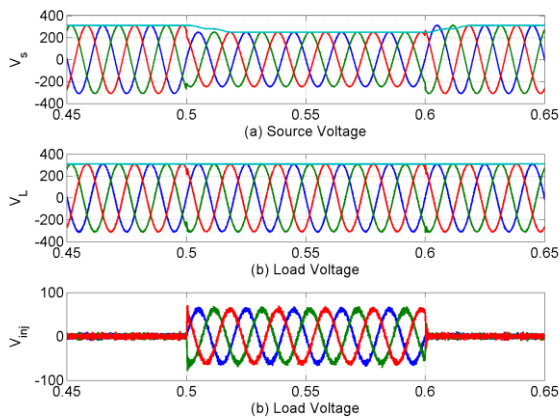

Fig 15. Mitigation of Sag in Load Voltage

Fig 15 shows the grid voltage contains 20% lower than the nominal value. Series active filter increases the value to nominal value. Here it is clear that UPQC compensated the entire power quality problem in distributed system.

7. CONCLUSION

In the research, the main objectives for the utilization of the studied equipment have been to reducing the distortion level occurring in the cases of harmonics generating loads in distribution networks and highly improving the power quality of the system. In order to protect critical loads from more voltage harmonics and current harmonics in the distribution network, the UPQC i.e., series connected voltage-source converter known as Dynamic Voltage Restorer and shunt connected voltage-source converter known as Dstatcom is suitable and satisfactory. Due to its reliability it was adopted as the optimal solution for the compensation of voltage and current. The MATLAB/SIMULINK were used to carry out extensive simulation studies on unified power quality conditioner and for the controlling purpose the proportional integral controller is used and adjustable speed drive is used as a load. Therefore, UPQC is considered to be an efficient solution. Unified power quality conditioner is capable of reducing the level of THD in the case of networks which are connected to the harmonics generating load (like ASD). All type of faults (single line to ground, double line to ground, three phase line to ground fault) are also compensated using UPQC.

REFERENCES

- [1] C. Sankaran, "Power Quality", *CRC Press LLC*, 2002.
- [2] Alexander Kusko and Marc T. Thompson, "Power Quality in Electrical Systems", *McGraw-Hill*, 2007.
- [3] Roger C. Dugan, Mark F. McGranaghan, Surya Santoso and H. Wayne Beaty, "Electrical Power Systems Quality", *The McGraw-Hill, Second Edition*, 2004.
- [4] K. R. Padiyar, "Facts Controllers in Power Transmission and Distribution", *New Age International Publishers*, 2007.
- [5] H. Hingorani, "Introducing Custom Power" *IEEE Spectrum*, Vol.32, Issue: 6, Page(s): 41-48, June 1995.

- [6] Juan W. Dixon, Gustavo Venegas and Luis A. Moran, "A Series Active Power Filter Based on a Sinusoidal Current-Controlled Voltage-Source Inverter" *IEEE Transactions on Industrial Electronics*, Vol. 44, Issue: 5, Page(s): 612 - 620, October 1997.

- [7] Yash Pal, A. Swarup, and Bhim Singh, "A Review of Compensating Type Custom Power Devices for Power Quality Improvement" *2008 Joint International Conference on Power System Technology (POWERCON) and IEEE Power India Conference New Delhi, India* Page(s): 1 - 8, October 2008.

- [8] Arindam Ghosh and Gerard Ledwith, "Power Quality Enhancement Using Custom Power Devices", *Kluwer Academic Publishers*, 2002.

- [9] Angelo Baghini, "Handbook of Power Quality", *John Wiley & Sons Ltd.*, 2008.

- [10] T. A. Short, "Distribution Reliability and Power Quality", *Taylor & Francis Group, CRC Press*, 2006, June 2009.

- [11] Mojtaba Nemati, Hesam Addin Yousefian and Rouhollah Afshari, "Recognize the Role of DVR in Power Systems", *International Journal of Recent Trends in Engineering*, Vol. 2, Page(s): 13 - 15, November 2009.

- [12] J. Barros, M. de Apraiz, and R. I. Diego, "Measurement of Subharmonics In Power Voltages", *Power Tech, IEEE Lausanne*, Page(s): 1736 - 1740, 2007.